



TECHNICAL BULLETIN

06/03

Removal of bungs on BPW disc braked axles

When the service and spring chambers are assembled to the disc brake calipers on BPW axles it is imperative that the lower bungs on the service and spring brake chambers are removed.

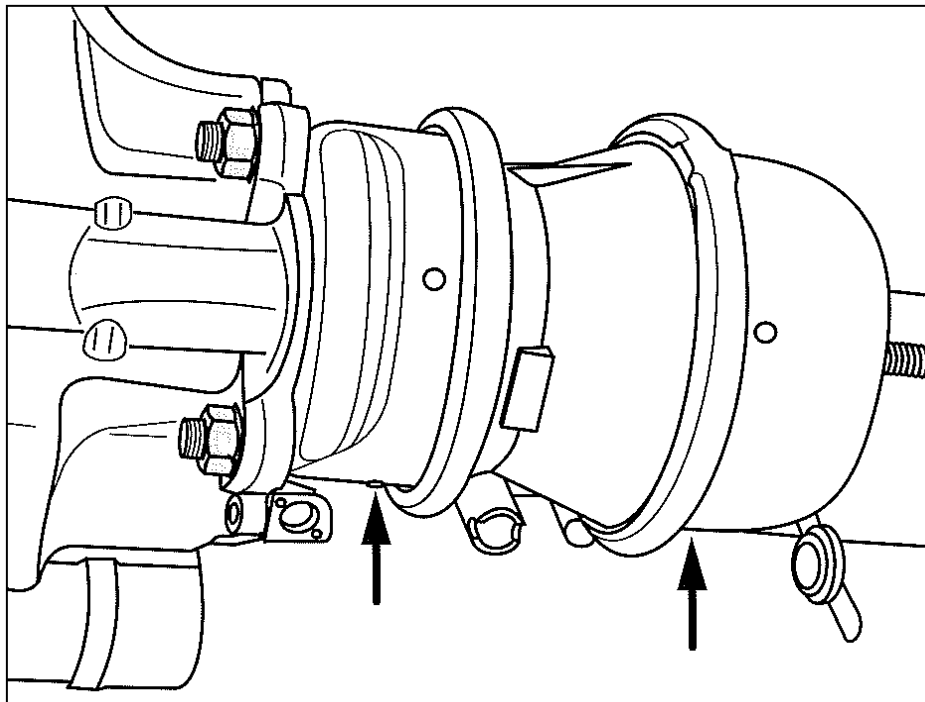

Removal of the lower bungs is important for the correct low pressure operation of the disc brake and for allowing condensate (water) to drain out. Leave all the other bungs in place.