



### AIRLIGHT II U BOLT REPLACEMENT

ISSUE 23/07

Replaces Issue 13/05

Whenever a BPW axle is assembled with **M22mm U bolts**

- U Bolts must be replaced in Pairs.
- All threads and nut/washer interfaces must be lubricated with grease.
- U Bolts must be tightened to 550 Nm + 90° tightening angle as per sequence below
- U Bolts must be retightened to 550 Nm before completing 2500Kms, and a First Service Inspection form returned to BPW Transport Efficiency
- U Bolts must have torque checked (550 Nm) during service inspections (annually)

Whenever a BPW axle is assembled with **M24mm U bolts**

- U Bolts must be replaced in Pairs.
- All threads and nut/washer interfaces must be lubricated with grease.
- U Bolts must be tightened to 650 Nm as per sequence below
- U Bolts must be retightened to 650 Nm before completing 2500Kms, and a First Service Inspection form returned to BPW Transport Efficiency (Fax 09 2738086)
- U Bolts must have torque checked (650 Nm) during service inspections (annually)

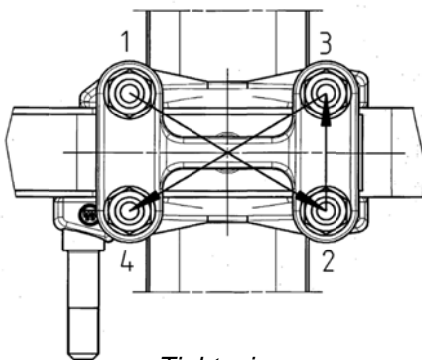

*Tightening sequence*

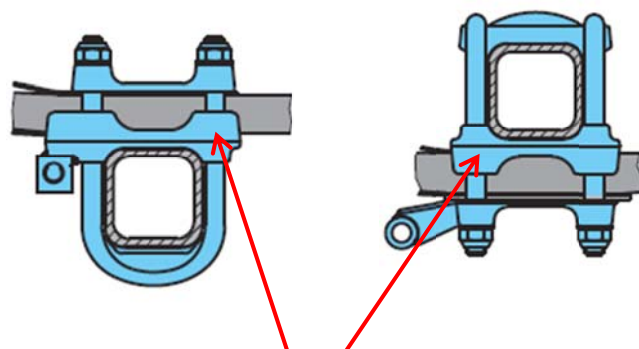

*Spring seat*

With all clamped suspensions, the spring seat that is sandwiched between the axle and trailing arm must be replaced as it has serrations where it sits around the axle which contribute to the clamping force