

BPW self-steering axles with disc and drum brake. Axle loads 9000 kg up to 10,000/12,000 kg.

SKH...LL

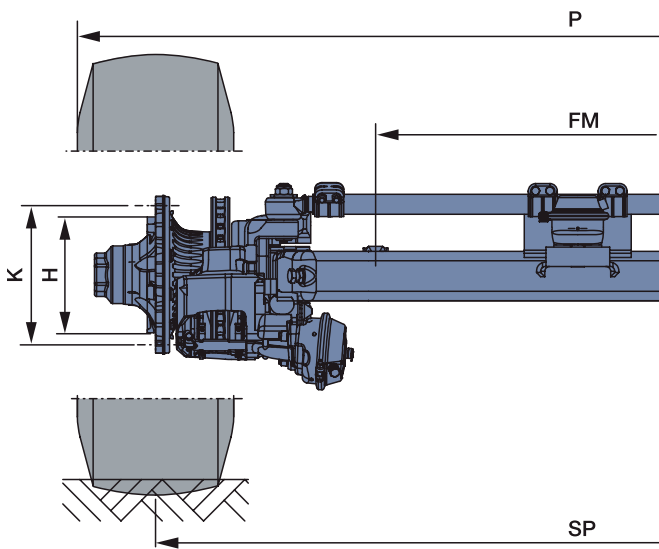

HSFH...LL

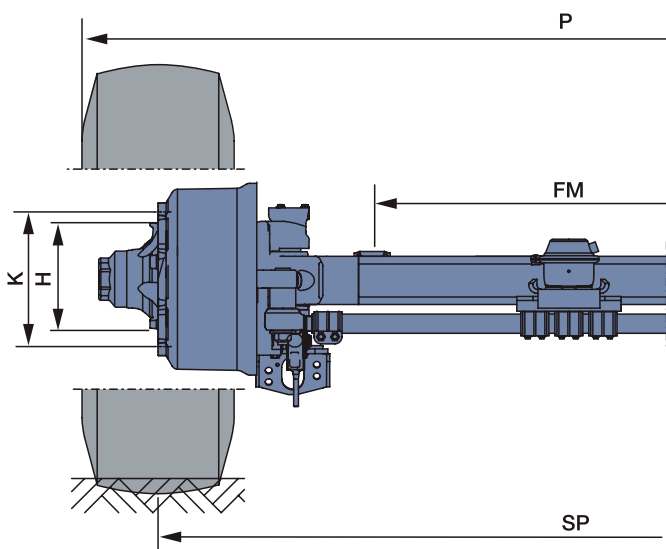

KMZ...LL

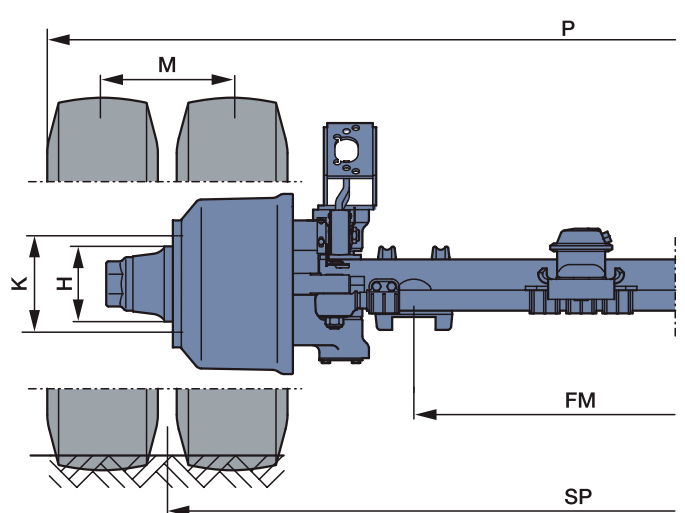



Axle type*	Permitted axle load up to 105 km/h [kg]	Brake	Track width SP [mm]	Spring centre FM [mm]	Axle cross section [mm]	Wheel connection				Overall width P [mm]	Axle weight ¹⁾ [kg]
						Wheel stud	Ø H/K [mm]	ET/M	Tyre example		
SKH...LL 9010	9000	SB 3745	2040	980	120x15	10 x M22 x 1.5	335/280.8	ET 0	385/65 R 22.5	2430	447
SKH...LL 9010	9000	SB 3745	2095	1080	120x15	10 x M22 x 1.5	335/280.8	ET 0	385/65 R 22.5	2485	450
SKHB...LL 9010	9000	SB 3745	2040	980	120x15	10 x M22 x 1.5	335/280.8	ET 120	385/65 R 22.5	2430	482
SKHB...LL 9010	9000	SB 3745	2095	1080	120x15	10 x M22 x 1.5	335/280.8	ET 120	385/65 R 22.5	2485	485
SH...LL 9010	9000	SB 4309	2040	980	120x15	10 x M22 x 1.5	335/280.8	ET 0	385/65 R 22.5	2430	461
SH...LL 9010	9000	SB 4309	2095	1080	120x15	10 x M22 x 1.5	335/280.8	ET 0	385/65 R 22.5	2485	464
SHB...LL 9010	9000	SB 4309	2040	980	120x15	10 x M22 x 1.5	335/280.8	ET 120	385/65 R 22.5	2430	496
SHB...LL 9010	9000	SB 4309	2095	1080	120x15	10 x M22 x 1.5	335/280.8	ET 120	385/65 R 22.5	2485	499
SM...LL 10110	10000	SB 4309	2035	980	120 solid	10 x M22 x 1.5	335/280.8	ET 0	425/65 R 22.5	2465	551
SM...LL 10110	10000	SB 4309	2095	1080	120 solid	10 x M22 x 1.5	335/280.8	ET 0	425/65 R 22.5	2525	558
SM...LL 10110	10000	SB 4345	2035	980	120 solid	10 x M22 x 1.5	335/280.8	ET 0	425/65 R 22.5	2465	565
SM...LL 10110	10000	SB 4345	2095	1080	120 solid	10 x M22 x 1.5	335/280.8	ET 0	425/65 R 22.5	2525	572
NHZ...LL 9010	9000	SN 3020	1985	840	120x15	10 x M22 x 1.5	225/175.8	M = 290	245/70 R 17.5	2535	436
NMZ...LL 12010	12000	SN 3020	1990	840	120 solid	10 x M22 x 1.5	225/175.8	M = 290	245/70 R 17.5	2535	474
KMZ...LL 12010	12000	SN 3620	1925	780	120 solid	10 x M22 x 1.5	225/175.8	M = 320	285/70 R 19.5	2540	665
HSFH...LL 9010	9000	SN 4218	2040	980	120x15	10 x M22 x 1.5	335/280.8	ET 0	385/65 R 22.5	2430	466
HSFH...LL 9010	9000	SN 4218	2095	1080	120x15	10 x M22 x 1.5	335/280.8	ET 0	385/65 R 22.5	2485	469
HSFH...LL 10010	10000	SN 4220	2040	980	150x16	10 x M22 x 1.5	335/280.8	ET 0	425/65 R 22.5	2470	529
HSFH...LL 12010	12000	SN 4220	2040	980	150x16	10 x M22 x 1.5	335/280.8	ET 0	445/65 R 22.5	2470	539

* M-version instead of F-version for hub centring aluminium wheel connection

¹⁾ Weight tolerances are within the permitted DIN tolerances for the particular production processes

Additional equipment: ABS, dust cover, wear sensing
 Additional types available on request