

Overcome the most
challenging requirements
and difficult ground



BPW
pendel axles

BPW pendel axles. The right balance of loading and unloading.

For the low loader trailers, semitrailers, special vehicles and module platforms, BPW offers pendel axles with reliable, easy to maintain technology and optimum size.

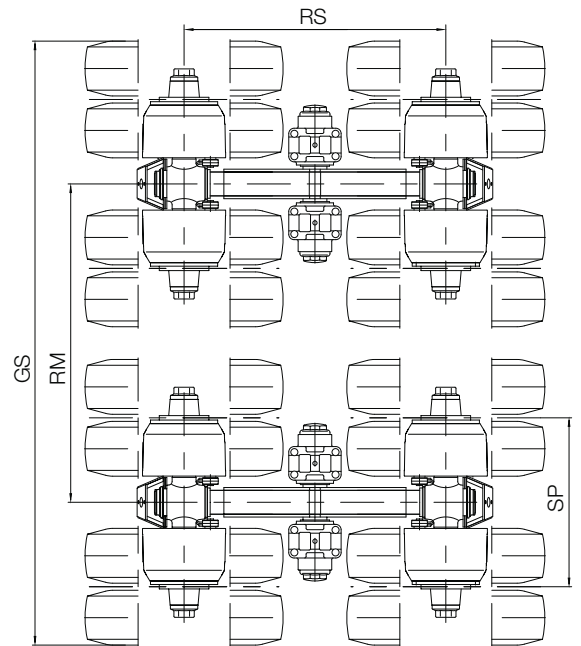
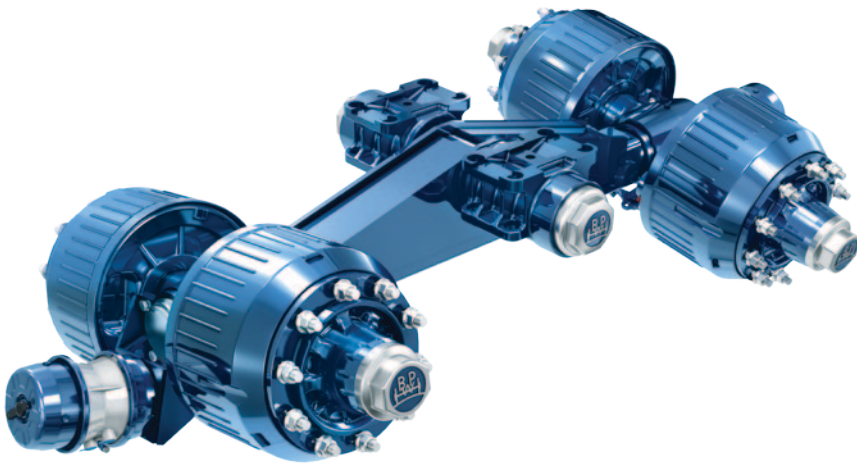

BPW tandem pendel axles for 15-inch to 24-inch tyres

Axle type	Axle load	Wheel connection	Brake	SP	RS	RM	GS	Tyres
NMZ ...	2 x 12 t	10xM22x1.5/Ø225/175.8	SN 3015	890	1350	1600	3025	235/75 R17.5
NMZ ...	2 x 13 t	10xM22x1.5/Ø225/175.8	SN 3020	950	1350	1800	3995	315/70 R15
MZF ...	2 x 12 t	10xM22x1.5/Ø335/280.8	SN 4220	960	1480	1800	3420	12,00-20
MZF ...	2 x 14 t	10xM22x1.5/Ø335/280.8	SN 4220	955	1480	1800	3417	12,00-20
MZM ...	2 x 16 t	10xM22x1.5/Ø335/280.8	SN 4220	960	1550	1840	3457	12,00-20
MZM ...	2 x 20 t	10xM22x1.5/Ø335/280.8	SN 4220	1125	1700	2170	4097	14,00 R20

BPW heavy-duty tandem pendel axles for industrial applications

Axle type	Axle load	Wheel connection	Brake	SP	RS	RM	GS	Tyres
MZM ...	2 x 40 t at 15 km/h	10xM24x1.5/Ø335/280.8	SN 4220	1120	1350	2000	3740	12,00-20 (CSE)
MZM ...	2 x 55 t at 10 km/h	24xM22x1.5/Ø425/370.8	SN 5020	1200	1575	2325	4376	14,00 R24

Additional designs on request, such as pendel axles without brake. Limit stops on pendel axles must be installed by the vehicle manufacturer.

Product features

- Axle loads 6 – 60 t
- ECO Plus hub system
- ABS, brake cylinders and ECO Master on request
- KTL_{Zn} coating

The specified axle loads are maximum values on the ground up to 105 km/h. In vehicles with a slower permitted maximum speed, the following axle load increases are possible: V_{max} 40 km/h +10%, V_{max} 25 km/h +25%, V_{max} 10 km/h +40%.

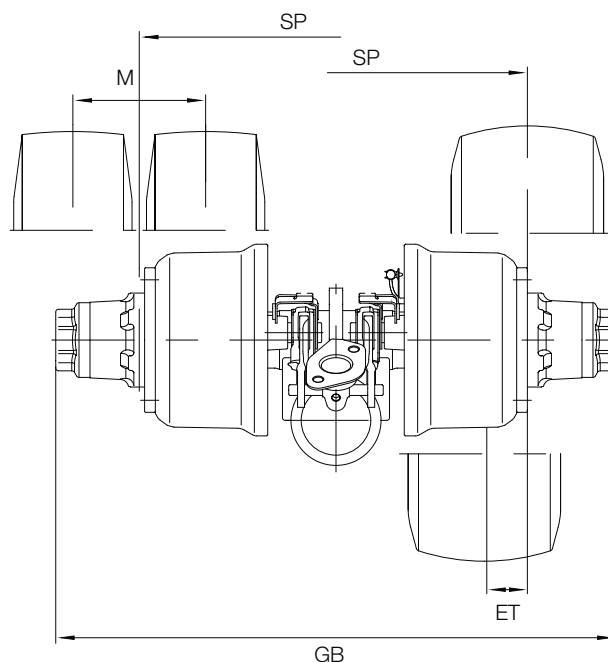

BPW pendel axles for 15-inch to 24-inch tyres

Axle type	Axle load	Wheel connection	Brake	SP	GB	ET/M	Tyres
NRD ...	6 t	10xM22x1.5/Ø225/Ø175.8	SN 3012	454	690	ET=55	245/70 R17.5
NRD ...	7 t	10xM22x1.5/Ø225/Ø175.8	SN 3012	518	794	ET=66	285/70 R19.5
NRD ...	9 t	10xM22x1.5/Ø225/Ø175.8	SN 3015	680	928	ET=0	285/70 R19.5
NRD ...	12 t*	10xM22x1.5/Ø225/Ø175.8	SN 3015	735	1047	M=248	215/70 R17.5
NRD ...	12 t	10xM22x1.5/Ø225/Ø175.8	SN 3020	910	1234	M=290	235/75 R17.5
NMZ ...	13 t	10xM22x1.5/Ø225/Ø175.8	SN 3020	800	1140	M=280	235/75 R17.5
MSF ...	12 t	10xM22x1.5/Ø335/Ø280.8	SN 4218	845	1189	ET=0	385/65 R22.5
MZM ...	14 t	10xM22x1.5/Ø335/Ø280.8	SN 4220	960	1306	M=350	12,00 R20
MZM ...	16 t	10xM22x1.5/Ø335/Ø280.8	SN 4220	960	1382	M=360	325/95 R24
MZM ...	20 t	10xM22x1.5/Ø335/Ø280.8	SN 4220	1120	1622	M=360	325/95 R24

* Technical axle load max. 9.7 t

BPW heavy-duty pendel axles for industrial applications

Axle type	Axle load	Wheel connection	Brake	SP	GB	ET/M	Tyres
NMZ ...	18 t bei 25 km/h	10xM22x1.5/Ø225/Ø175.8	SN 3020	800	1140		15" pneumatic and CSE tyres
RDB ...	25 t bei 5 km/h	10xM22x1.5/Ø335/280.8	SN 4218	600	974	ET=66	385/55 R22.5
MZM ...	40 t bei 15 km/h	10xM24x1.5/Ø335/280.8	SN 4220	1120	1581		20" pneumatic and CSE tyres
MZM ...	60 t bei 5 km/h	24xM22x1.5/Ø425/370.8	SN 5020	1320	1799		from 24" pneumatic tyres



We go the economical way!

BPW is a globally leading manufacturer of intelligent running gear systems for drawbar trailers and semi-trailers. From the axle via the suspension and brake to user-friendly telematics applications for efficient fleet management, we can provide you with complete one-stop trailer running gear supplies. As an owner-managed company, BPW is consistently focused on one goal: to always offer you precisely the solution which pays off for you in the end. In line with this, we focus on total quality to ensure high reliability and life expectancy, weight and time saving designs ensuring lower operating and maintenance costs as well as personalised customer service and a tight knit service network to provide quick and direct support. You can rest assured that with BPW you are always following the economical route.

